

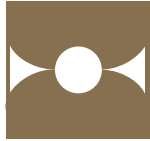

Marker



Tack



Magnetic

evolve™



Sophisticated. Uniquely Adaptive. Visual Communication.



C O N N E C T™ 
by Claridge.

let your ideas flow™

evolve™



Sophisticated. Uniquely Adaptive. Visual Communication.



Marker



Tack

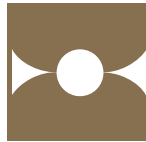

Magnetic

Features:

- Markerboards in LCS³ projection friendly porcelain enamel steel – the optimal surface for writing and erasing
- Tackboards in Claridge Cork, Guilford, Carnegie or pre-approved COM fabrics
- Contrasting wide face trim at top and bottom; narrow trim at sides
- Aluminum satin anodize trim also available with optional powder coat painted finish
- Concealed hanging system
- Contemporary style accessory tray is approximately 2" deep and firmly snaps into bottom trim
- GREENGUARD Indoor Air Quality and Children & Schools Certified porcelain writing surface

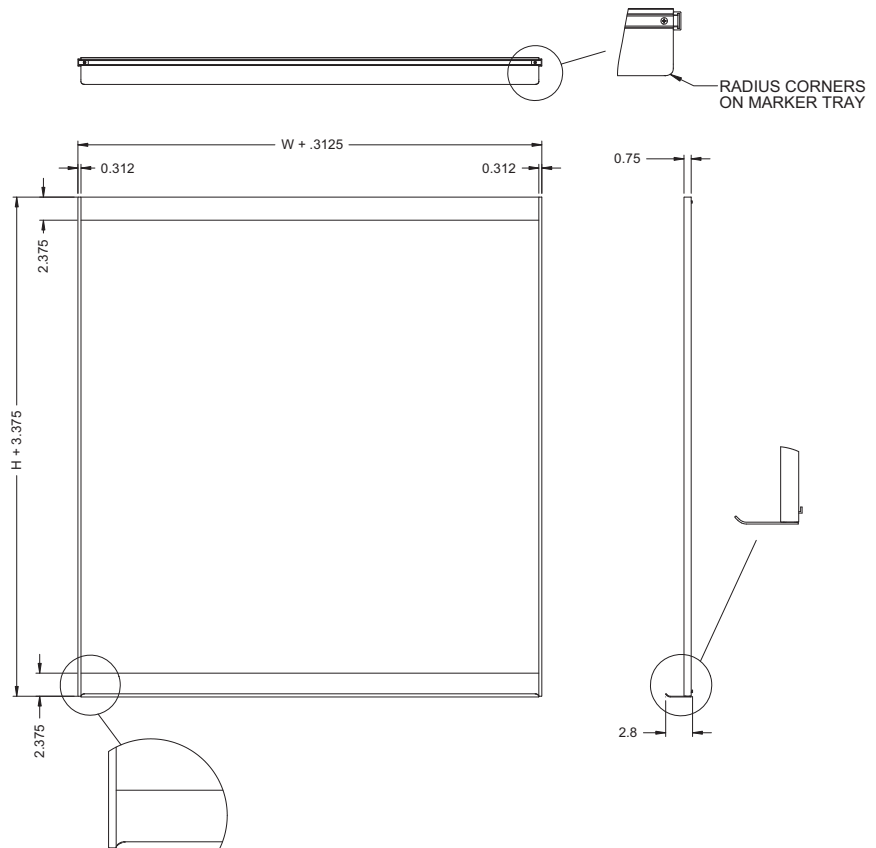

evolve™ Markerboards & Tackboards



Product Number	Nominal Dimensions	Porcelain MB	Est. Weight	Claridge Cork	Est. Weight	Fabric	Est. Weight
EV-0404-	4'0" (H) x 4'0" (W)	-MB	56 lbs.	-CO	48 lbs.	-FG or -FC	36 lbs.
EV-0405-	4'0" (H) x 5'0" (W)	-MB	70 lbs.	-CO	60 lbs.	-FG or -FC	45 lbs.
EV-0406-	4'0" (H) x 6'0" (W)	-MB	84 lbs.	-CO	72 lbs.	-FG or -FC	54 lbs.
EV-0408-	4'0" (H) x 8'0" (W)	-MB	112 lbs.	-CO	96 lbs.	-FG or -FC	72 lbs.
EV-0504-	5'0" (H) x 4'0" (W)	-MB	70 lbs.	-CO	60 lbs.	-FG or -FC	45 lbs.
EV-0506-	5'0" (H) x 6'0" (W)	-MB	105 lbs.				
EV-0508-	5'0" (H) x 8'0" (W)	-MB	140 lbs.				
EV-0604-	6'0" (H) x 4'0" (W)			-CO	72 lbs.	-FG or -FC	54 lbs.

Freight Class 70 (MB) Porcelain Markerboard, Tack surface available with Claridge Cork (CO), Guilford fabric (FG), Carnegie fabric (FC)
 Example: EV-0604-CO = Claridge cork. Other Sizes Available.